

2360 Boswell Road
Chula Vista, CA 91914
Phone 619.216.1444
Fax 619.216.1474
E-Mail tech@explorerprocomp.com



PRO COMP SUSPENSION

Suspension Systems that Work!

**PART# 13129
2005/2006
TOYOTA TACOMA
4WD/2WD Pre Runner
ADD-A-LEAF**

This document contains very important information that includes warranty information and instructions for resolving problems you may encounter. Please keep it in the vehicle as a permanent record.

Part #	Description	Qty.	Illus.	Page
13129	ADD-A-LEAF	2	1	5
90-3825	HARDWARE PACK: Add-A-Leaf	1	-	-
98-00250-1	2 1/2" Spring Plate- Clamps	4	1	5
98-00250-1	2 1/2" Spring Plate- Straps	4	1	5
97-380	3/8" X 5" Center Bolt	2	1	5
8337-1	3/8" Fine Gr. 8 Nut	2	1	5

Optional Equipment Available from your Pro Comp Distributor!

Traction Bars: 72500B

Mounting kit: 72083B

Skid Plate: 57196

Carrier Bearing Shim Kit: 90-6457

Light Bar: 25000

CV Style Driveshaft: 57098

Also, Check out our outstanding selection of Pro Comp tires to compliment your new installation!

Introduction:

- ◆ This installation requires a professional mechanic!
- ◆ We recommend that you have access to a factory service manual for your vehicle to assist in the disassembly and reassembly of your vehicle. It contains a wealth of detailed information.
- ◆ Prior to installation, carefully inspect the vehicle's steering and driveline systems paying close attention to the tie rod ends, ball joints, wheel bearing preload, pitman and idler arm. Additionally, check steering-to-frame and suspension-to-frame attaching points for stress cracks. The overall vehicle must be in excellent working condition. Repair or replace all worn or damaged parts!
- ◆ Read the instructions carefully and study the illustrations before attempting installation! You may save yourself a lot of extra work.
- ◆ Check the parts and hardware against the parts list to assure that your kit is complete. Separating parts according to the areas where they will be used and placing the hardware with the brackets before you begin will save installation time.
- ◆ Check the special equipment list and ensure the availability of these tools.
- ◆ Secure and properly block vehicle prior to beginning installation.
- ◆ ALWAYS wear safety glasses when using power tools or working under the vehicle!
- ◆ Use caution when cutting is required under the vehicle. The factory undercoating is flammable. Take appropriate precautions. Have a fire extinguisher close at hand.
- ◆ Foot pound torque readings are listed on the Torque Specifications chart at the end of the instructions. These are to be used unless specifically directed otherwise. Apply thread lock retaining compound where specified.
- ◆ **Please note that while every effort is made to ensure that the installation of your Pro Comp lift kit is a positive experience, variations in construction and assembly in the vehicle manufacturing process will virtually ensure that some parts may seem difficult to install. Additionally, the current trend in manufacturing of vehicles results in a frame that is highly flexible and may shift slightly on disassembly prior to installation. The use of pry bars and tapered punches for alignment is considered normal and usually does not indicate a faulty product. However, if you are uncertain about some aspect of the installation process, please feel free to call our tech support department at the number listed on the cover page. We do not recommend that you modify the Pro Comp parts in any way as this will void any warranty expressed or implied by the Pro Comp Suspension company.**

INSTALLATION INSTRUCTIONS:

NOTE: *In order to properly install the add-a-leaf spring, it will be necessary to contain the elasticity in the leaf spring with “C” clamps when the center bolts are removed. Some springs have a factory helper spring consisting of one or more flat leaves installed at the bottom of the leaf pack. DO NOT install the add-a-leaf spring in or below the helper spring.*

1. Measure the vehicle from the center of the hub to the fender lip and record this measurement below.

LF: _____ RF: _____

LR: _____ RR: _____

2. Block the front tires and raise the rear of the vehicle. Support the frame with jack stands forward of the rear springs.
3. Remove the rear wheels.
4. Unbolt the shocks at the lower shock mount on both sides of the vehicle. It may be necessary that you slightly raise the axle to unload the shocks for removal.
5. Work on one side of the vehicle at a time.
6. Support the rear axle with a floor jack and remove the **U-bolts** on the driver side. Loosen the **U-bolts** on the passenger side and lower the rear axle.

NOTE: *Be sure not to over extend the rear brake lines.*

7. Use C-clamps to hold the leaves of the rear leaf spring together and remove spring center bolt.
8. Disassemble the leaf spring and insert the add-a-leaf (**13129**). See ILLUSTRATION 1.

NOTE: *Add-a-leaf will be placed in the spring assembly progressively according to length. For example, if the existing leaves are 32” long and 25” long and the add-a-leaf is 28” long, place the add-a-leaf between the existing leaves.*

9. Using the C-clamps, re-clamp and bolt the leaf pack back together using the supplied center bolt (**97-380**) with the head of the bolt facing down. See ILLUSTRATION 1.
10. Install the lift block (*If the vehicle is equipped with one*), making sure the pins fit properly into the holes on the spring perch. Use your floor jack to raise the axle to the spring. Make sure the pin on the leaf spring fit into the holes on the new lift block. See ILLUSTRATION 1.

NOTE: *These blocks are slightly tapered and the short side of the taper is oriented to the front of the vehicle,*

11. Secure the assembly with the **U-bolts** and high-nuts and washers. Do not torque the U-

bolts at this time. See ILLUSTRATION 1.

NOTE: Make sure the block sits flush on the axle perch.

12. Repeat the installation on the other side of the vehicle.
13. When the installation of the remaining side is complete, torque the **U-bolts** to **85** ft./lbs.
14. Reinstall shocks to the lower axle mount.
15. Reinstall the wheels and tires and lower the vehicle to the ground. Torque the wheels to the manufacturers recommended specifications.
16. Recheck the wheel lug torque on all four wheels at this time.
17. Recheck all hardware for proper installation and torque at this time.
18. On completion of the installation, have the suspension and headlights re-aligned.
19. After 100 miles recheck for proper torque on all newly installed hardware.
20. Recheck all hardware for tightness after off road use.

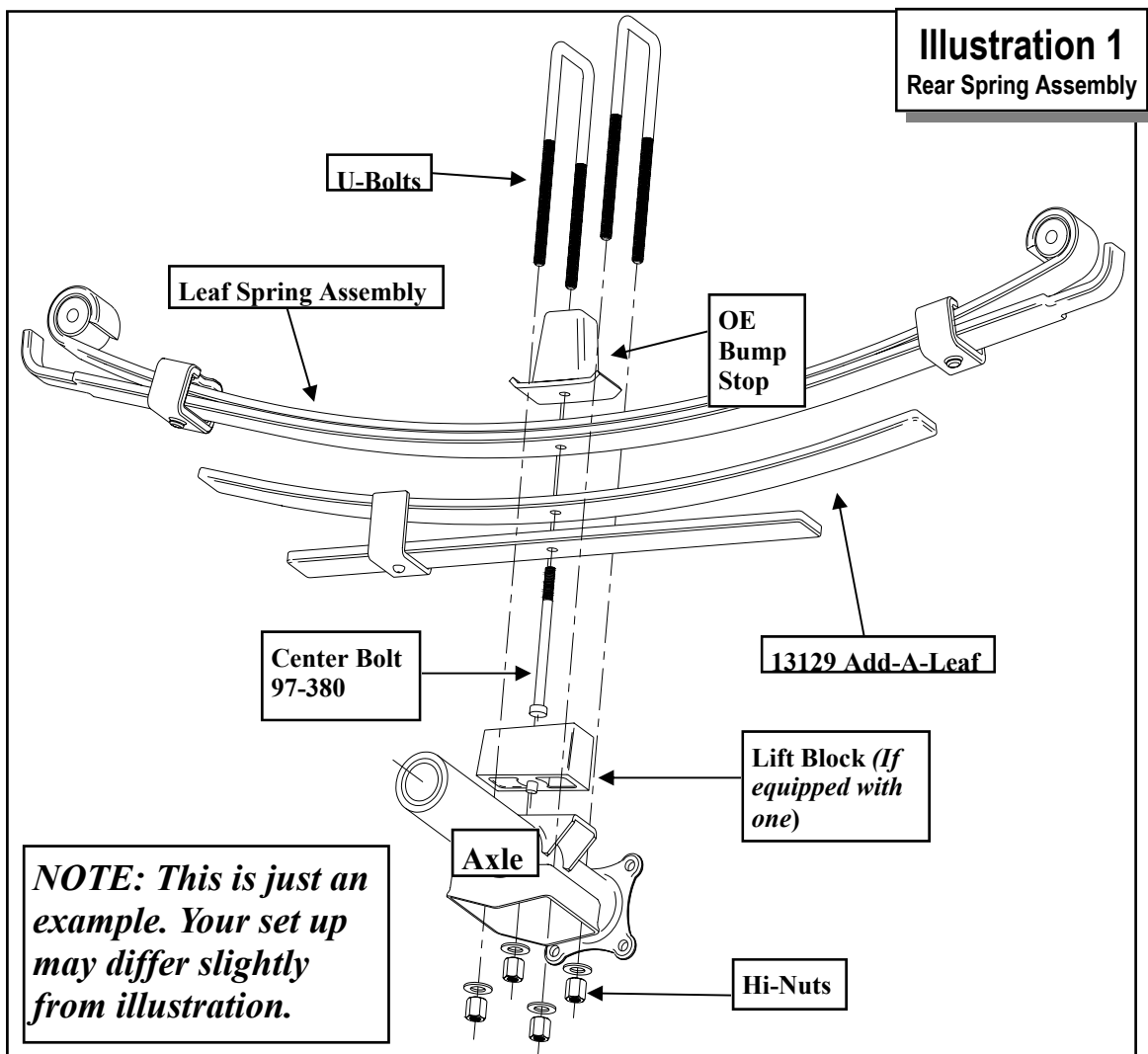

Notice to Owner operator, Dealer and Installer:

Vehicles that have been enhanced for off-road performance often have unique handling characteristics due to the higher center of gravity and larger tires. This vehicle may handle, react and stop differently than many passenger cars or unmodified vehicles, both on and off-road. You must drive your vehicle safely! Extreme care should always be taken to prevent vehicle rollover or loss of control, which can result in serious injury or even death. Always avoid sudden sharp turns or abrupt maneuvers and allow more time and distance for braking! Pro Comp reminds you to fasten your seat belts at all times and reduce speed! We will gladly answer any questions concerning the design, function, maintenance and correct use of our products.

Please make sure your Dealer/Installer explains and delivers all warning notices, warranty forms and instruction sheets included with Pro Comp product.

Application listings in this catalog have been carefully fit checked for each model and year denoted. However, Pro Comp reserves the right to update as necessary, without notice, and will not be held responsible for misprints, changes or variations made by vehicle manufacturers. Please call when in question regarding new model year, vehicles not listed by specific body or chassis styles or vehicles not originally distributed in the USA.

Please note that certain mechanical aspects of any suspension lift product may accelerate ordinary wear of original equipment components. Further, installation of certain Pro Comp products may void the vehicle's factory warranty as it pertains to certain covered parts; it is the consumer's responsibility to check with their local dealer for warranty coverage before installation of the lift.

Warranty and Return policy:

Pro Comp warrants its full line of products to be free from defects in workmanship and materials. Pro Comp's obligation under this warranty is limited to repair or replacement, at Pro Comp's option, of the defective product. Any and all costs of removal, installation, freight or incidental or consequential damages are expressly excluded from this warranty. Pro Comp is not responsible for damages and / or warranty of other vehicle parts related or non-related to the installation of Pro Comp product. A consumer who makes the decision to modify his vehicle with aftermarket components of any kind will assume all risk and responsibility for potential damages incurred as a result of their chosen modifications. Warranty coverage does not include consumer opinions regarding ride comfort, fitment and design. Warranty claims can be made directly with Pro Comp or at any factory authorized Pro Comp dealer.

IMPORTANT! To validate the warranty on this purchase please be sure to mail in the warranty card.

Claims not covered under warranty-

- Parts subject to normal wear, this includes bushings, bump stops, ball joints, tie rod ends and heim joints
 - Discontinued products at Pro Comp's discretion
- Bent or dented product
- Finish after 90 days
- Leaf or coil springs used without proper bump stops
- Light bulbs
- Products with evident damage caused by abrasion or contact with other items
- Damage caused as a result of not following recommendations or requirements called out in the installation manuals
- Products used in applications other than listed in Pro Comp's catalog
- Components or accessories used in conjunction with other manufacturer's systems
- Tire & Wheel Warranty as per Pro Competition Tire Company policy
- Warranty claims without "Proof of Purchase"
- Pro Comp Pro Runner coil over shocks are considered a serviceable shock with a one-year warranty against leakage only. Rebuild service and replacement parts will be available and sold separately by Pro Comp. Contact Pro Comp for specific service charges.
- Pro Comp accepts no responsibility for any altered product, improper installation, lack of or improper maintenance, or improper use of our products.

E-Mail: tech@explorerprocomp.com
 Website: www.explorerprocomp.com
 Fax: (619) 216-1474
 Ph: (619) 216-1444

<p>PLACE WARRANTY REGISTRATION NUMBER HERE: _____</p>
--